

(122/10)

The Haryana Pond and Waste Water Management Authority

Plot No-9, DHL Square, 3rd Floor, IT Park, Sector-22, Panchkula

E-Mail Id: ms.haryanapondauthority@gmail.com

Website: www.hpwwma.org.in

Letter No:-HPWWMA/2024/ADMN/0023A/ 151

Dated:- 10/01/2024

NOTICE INVITING QUOTATION(2nd call)

Sealed quotations are invited for Providing & Fixing of Name Plates for Officers Rooms & Staff Cabins of HPWWMA at 3rd floor, DHL Square, Sec-22, Panchkula in single stage two cover systems i.e. Technical Bid and Financial Bid (comprising of price bid proposal).

Schedule – A

S. No.	PARTICULARS.	REMARKS
1	Ref. Number	HPA/ADMN/2023/0023/
2	Last date & time of bid submission by	31 -01-2024(15:00 hrs.).
3	Date & Time of opening of Technical Bids	31 -01-2024 (15:30 hrs.)
4	Date & Time of opening of Financial Bids	To be decided later on.
6	Bid validity	03 Months.

Under this process, the technical bid applications as well as financial bids are invited at single stage under two sealed covers i.e., Technical & Financial envelopes. The bidder has to put all the papers required for eligibility criteria in the envelope marked as “Technical Bid”.

The rates are to be quoted in prescribed “ANNEXURE-I” and put in other envelope marked as “Financial Bid”.

Both the envelopes to be put in main envelope marked as “Quotation for Providing & Fixing of Name Plates for Officers Rooms & Staff Cabins of HPWWMA at 3rd floor, DHL Square, Sec-22, Panchkula”.

Eligibility of the applicants will be first examined based on the details submitted under first cover i.e., technical bid with respect to eligibility criteria prescribed in this document. The financial bid under the second cover shall be opened for only those applicants, who qualify the technical bid as per the eligibility criteria as per the document.

122/C

Bidders can submit their bids through post or put in tender box lying in the office of HPWWMA.

Terms and Conditions.

1. No advance payment will be made.
2. The HPWWMA will not accept any duplicate/ substandard items. If the supplier is not able to supply the items as per make/ sample action may be taken against the firm i.e. imposition of penalty.
3. If the supplied items are found defective and not up to the mark, the same should be replaced within a period of 2 days.
4. The firm should be registered with the Government for the purpose of Tax-GST etc. and the certified copies should be attached with the bid documents.
5. Rates should be quoted in the prescribed Pro-forma as **ANNEXURE-I**. The rates should be inclusive of all taxes & nothing extra will be paid.
6. The competent authority in the HPWWMA reserves the right to amend any of the terms and conditions contained in the Quotation Documents after giving required notice. The decision of competent authority in this regard will be final and binding.
7. Duly constituted committee shall open and evaluate the bids and accordingly accept the bid(s) on the basis of lowest quote and quality of sample of non-branded items.
8. In case, the supplier is found to have breached any condition(s) of the contract at any stage or services of the supplier is found not be to the satisfaction of the HPWWMA, the contract may be terminated. The decision of the HPWWMA, in this regard, shall be final and binding.
9. The bidder has to give a declaration in the attached form as (**ANNEXURE-III**) that he has not been black listed/ debarred by any the Government or its PSUs.
10. Any dispute, subject to Panchkula Jurisdiction only.

Vender Eligibility criteria: -

1. Bidder should possess valid GST Number. Attested copy of the same must be submitted with the Bid.
2. The bid shall be valid for three months after the date of opening of Technical Bid.
3. Information furnished by the Firm/Supplier/Bidder as per ANNEXURE-II should be self-attested.
4. The Bidder should not have been blacklisted by any of the Department/ Ministry/ Organization. A duly signed declaration to this effect must be submitted along with technical bid (ANNEXURE-III).
5. The invitation is open to all manufactures, their authorized suppliers and general order suppliers, who are having at least 03 years of experience in Providing & Fixing of Name Plates for Officers Rooms & Staff Cabins to the Govt. offices or Govt. Undertakings Organizations etc.
6. Haryana Pond and Waste Water Management Authority shall reject bid, if it determines that bidder recommended for award has engaged in corrupt or fraudulent practice while competing for this contract.

09/01/24

Technical Advisor
HPWWMA, Panchkula.

ANNEXURE-I**Name of Work:-Providing & Fixing of Name Plates for Officers Rooms & Staff Cabins of HPWWMA at 3rd floor, DHL Square, Sec-22, Panchkula**

S/N	Description Items	Unit	Qty.	Rate (In Rs. Incl. All Taxes)	Amount (In Rs. Incl. All Taxes)
1	Providing & fixing name plates with sliders and frames made of acrylic sheet depicting name and designation of officers with white pasting tape for the officers rooms of HPA, as shown in the drawing (Annexure-A) and as per the direction of Member Secretary, HPA.[Photographs-I & II]	Each	13		
2	Providing & fixing name plates on sheet made of acrylic sheet depicting only designation with white pasting tape for the staff cabins of HPA as shown in the drawing (Annexure-A) and as per the direction of Member Secretary, HPA. .[Photograph- III]	Each	42		
Total Amount					

Terms & Conditions:-

1. Installations charges are included in the price.
2. Final payment will be made after successful completion of the work.
3. Work should be completed within 15 days of issue of this order positively .
4. The work should be executed as per direction of Member Secretary, HPA.
5. The rate should be inclusive of all taxes of any type i/c GST.

(Signature of Authorized Person)

122⁴/_c

ANNEXURE-II

Information to be Furnished by the Firm/Supplier:-

Sr. No	Particulars	To be filled by the Suppliers
1.	Name of Firm/Agency	
	Address	
	Name of Proprietor	
	Telephone no.	
	Mobile No.	
	Email. Address	
	Name of Business partner, if any	
2.	PAN Number (Copies to enclosed)	
3.	CST/VAT Registration Certificates (Copies to enclosed along with TIN numbers)	
4.	Service TAX Registration no. copies to enclosed	
5.	Where terms and conditions is acceptable or not?	
6.	Whether the firms is blacklisted by any Government/Department or any criminal case is registered against the firm or its own/partners anywhere in India (if No, an undertaking to this effect may be attached.	

Date:-

.....
Signature of Authorized Person

Name.....

Address.....

1220

ANNEXURE-III

Declaration

To

Member Secretary,
Haryana Pond & Waste Water Management Authority.
Plot No.-9, DHL Square, 3rd Floor, IT Park, Sector-22, Panchkula-134109.

R/Sir,

I/We.....
..hereby confirm that our firm has not been banned o blacklisted by any government organization/ Financial Institution/ Court/ Public Sector Unit/ Central Government and no Police /Vigilance enquiry/Criminal case is pending against us.

Date:-

.....
Signature of Authorized Person

Name.....

Address.....

Mob. No.....

129/C

ANNEXURE - A

DETAIL OF NAME PLATES FOR OFFICER'S ROOMS AND STAFF CABINS

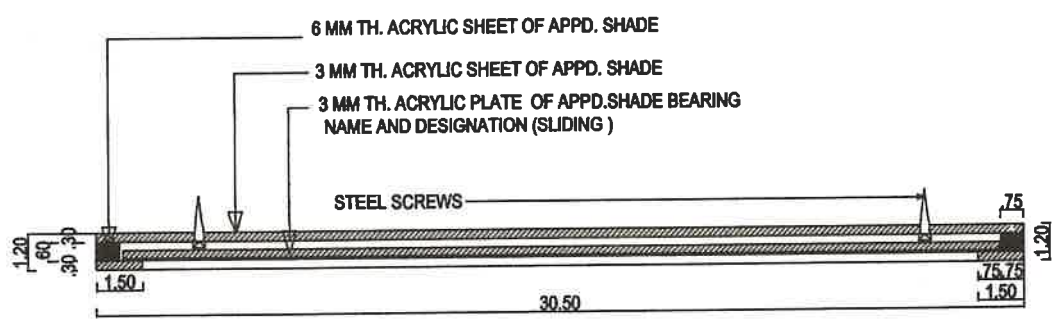

SECTION - AA
(NTS)

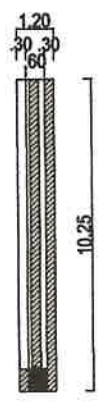

SECTION AT - BB
(NTS)

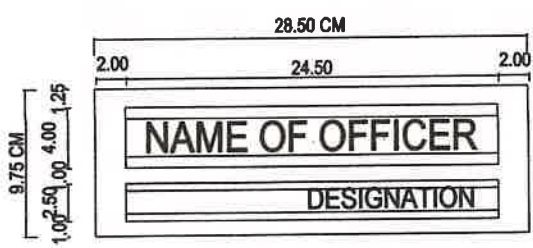

DETAIL OF PLATE WITH NAME AND DESIGNATION (MOVEABLE)



DETAIL OF NAME PLATE 'B' SIDE ELEVATION FOR STAFF CABINS TO BE PASTED AT ENTRANCE

(13)

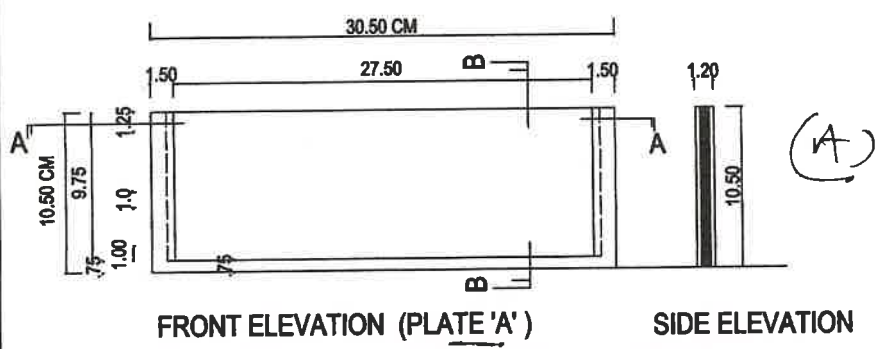

FRONT ELEVATION (PLATE 'A')

SIDE ELEVATION

DETAIL OF NAME PLATE 'A' FOR OFFICER'S ROOM (TO BE SCREWED AT ENTRANCE)

रवीन्द्र कुमार शर्मा
कार्यकारी अभियन्ता

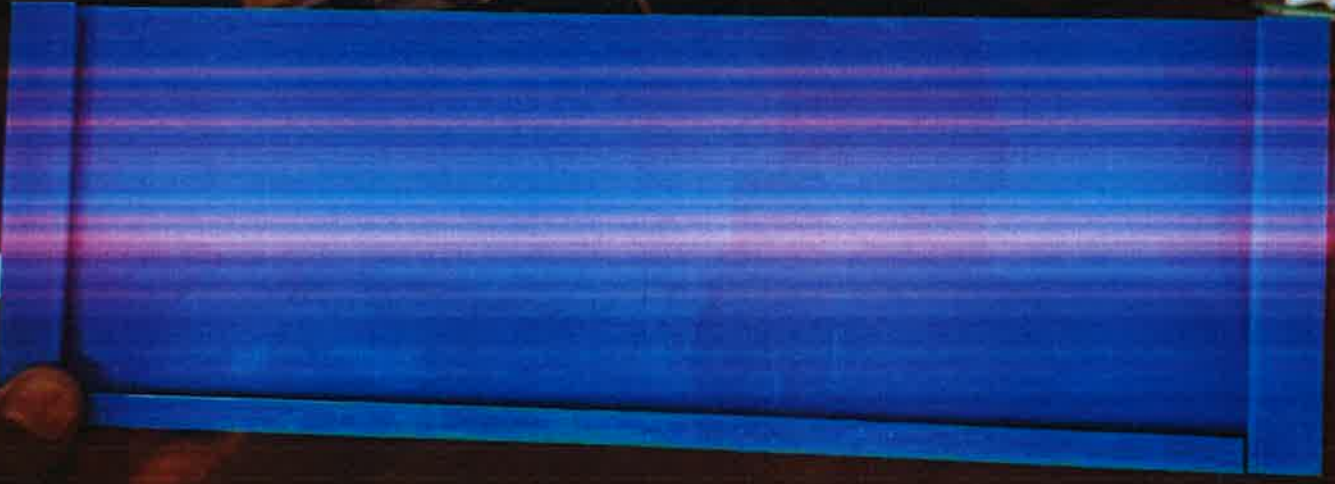

रवीन्द्र कुमार शर्मा
कार्यकारी अभियन्ता

SAMPLE | 1410106484TH-II

12/28

सहायक अभियन्ता - I

Stamp

[Photograph - III]

(12/1/21)

